



Manual DST Series

ATESTEO GmbH & Co. KG
Konrad-Zuse-Str. 3
52477 Alsdorf
Germany

Telephone +49 2404 9870-580
E-Mail service-pm@atesteo.com
www.atesteo.com

List of content

1	Introduction	5
1.1	Manufacturer	6
1.2	Background	6
1.3	Disposal and environment	7
2	Safety Instructions	8
2.1	General safety instructions	8
2.2	Explanation of symbols and notice	9
2.3	Appropriate use	10
2.4	Modifications/conversions	10
2.5	Operator's responsibility	11
2.6	Safety notes for assembly	14
2.7	Safety notes for operation	15
2.8	Load limits	16
3	System description	17
3.1	Specifications	18
3.2	Features	19
4	Installation	20
4.1	Mechanical installation	20
4.1.1	Part list	20
4.1.2	Mounting	21
4.1.3	Mechanical dimensions	23
4.2	Electrical installation	25
4.2.1	Power Supply	26
4.2.2	Earthing	26
4.2.3	Connecting the torque meter with a data acquisition system	27
5	Features & interfaces	29

5.1	Speed measuring system	29
5.2	Overvoltage protection	29
5.3	Analog Output	29
5.4	USB interface (UART interface)	30
5.4.1	Port settings	30
5.4.2	Sending information	30
5.4.3	Command overview	31
5.4.4	Command details	32
5.5	Enhanced system commands	36
5.5.1	Receiving information	36
5.5.2	Watchdog	37
5.5.3	Torque	37
5.5.4	Speed	37
5.5.5	System state	37
5.5.6	Datasheet	39
5.5.7	Vs-Rotor	40
5.5.8	Temp. & Temp.-Max	40
5.5.9	Digital Interface	41
5.6	LED	42
6	Connections	43
6.1	Plug connection at DST	43
6.1.1	X800	43
6.1.2	USB	43
6.2	Cable connection	43
6.2.1	X800	43
6.2.2	USB	45
7	General references	46
7.1	Resetting the zero point	46
7.1.1	Thermal influences	46

7.1.2	Hysteresis-caused influences	46
7.1.3	Aging	47
7.1.4	Lateral force influence	47
7.1.5	General	47
7.1.6	Clipping	48
7.2	CE Manufacturer's Declaration:	48
8	Appendix	49
8.1	Table of figures	49
8.2	Table of tables	49

1 Introduction

Thank you for choosing ATESTEO GmbH & Co. KG quality product. Please read the system description carefully so you make the most of the versatile features of your product.

This operating manual is a component of the DST series and should always be carefully kept with the DST series until it is disposed of.

It is impossible to eliminate every danger to persons or material that the DST series might present. For this reason, every person working at the DST series or is involved in its transport, setting up, control, maintenance or repair must be properly instructed and be informed of the possible dangers.

For this purpose, the operating instructions and, especially, the safety instructions must be carefully read, understood and observed.

Company ATESTEO GmbH & Co. KG reserves the right to carry out changes at its products, which serve the technical further development the company ATESTEO GmbH & Co. KG. These changes aren't documented expressly in every individual case.

This operator's manual and the information contained in it were compiled with the advisable care.

Company ATESTEO GmbH & Co. KG takes on no liability for misprints or other faults or damages resulting from it.

The brands mentioned in this operator's manual and product names are trademarks or registered trademarks of the respective title holders.

Please do not miss to contact us if there is anything in the operating instructions that you cannot clearly understand. We are grateful for any kind of suggestion or criticism that you may wish to make; please let us know or write to us. This will help us to make the operating instruction still more user-friendly in taking account of your wishes and requirements.

1.1 Manufacturer

ATESTEO GmbH & Co. KG
Konrad-Zuse-Straße 3
52477 Alsdorf
Germany

<http://www.atesteo.com>

T +49 (0) 2404 9870 - 0

Service: service-pm@atesteo.com

1.2 Background

In this manual you will find all steps which are necessary to start-up the ATESTEO torque and speed measurement system.

This manual is usable for the following types of torque meters:

Torque meter DST 5

Torque meter DST 10

Torque meter DST 20

All measurement systems work contactless and are maintenance-free. The data transfer is realized by a frequency modulated infrared transmitter. The power of the rotating electronic module works inductive.

1.3 Disposal and environment

Electrical and electronic products are subject to special conditions for disposal. Proper disposal of old equipment prevents health hazards and environmental damage.

Packaging

The original packaging of ATESTEO equipment can be recycled, as it is made of recyclable material. However, you should keep the packaging for at least the warranty period. In the event of a complaint, the torque flange, as well as the accessories, must be returned in the original packaging.

Due to ecological aspects, the return of the empty packaging should be waived.

Legally prescribed labeling for disposal



Electrical and electronic devices bearing the symbol  are subject to European Directive 2002/96 / EC on waste electrical and electronic equipment. The symbol indicates that waste equipment that is no longer usable must be disposed of separately from regular household waste in accordance with European environmental protection and recycling regulations.

However, the disposal regulations vary from country to country, which is why we ask you, if necessary, your supplier how to dispose your waste.

2 Safety Instructions

2.1 General safety instructions

The manual must be read carefully before start-up, maintenance work or any other work on the torque measuring system. Prerequisite for the safe and proper handling of the equipment knows all safety instructions and safety regulations of the attachment.

Every DST needs to be correctly mounted and fully functional before any start-up.

Shafts or adapters mounted to the torque meter must be properly designed, so that critical bending moment is avoided.

Exclusively qualified laborers are allowed to do maintenance work on any electrical components (see chapter Qualified personnel).

If the torque meter is sold on, these safety instructions must be included.

Note on additional standards:



Low Voltage Directive 73/23/EWG, Electromagnetic Compatibility Directive 89/336/EWG and the harmonized standards



DIN EN 292-1 Safety of machinery



DIN EN 292-2 Safety of machinery



Maintenance and inspections on the electrical equipment are to be executed by trained personal. Non-designated use and modifications of the measurement system will make the EG-Conformity declaration invalid.

2.2 Explanation of symbols and notice

Warnings

Warnings are indicated by symbols in these safety instructions. The hints are going through

Signal words are introduced, which express the extent of the hazard. It is imperative that you follow the instructions and act with care to avoid accidents, personal injury and material damage.



Information

Draws attention to important information about correct handling.



Caution

Warns of a potentially dangerous situation in which failure to comply with safety requirements can result in slight or moderate physical injury.

2.3 Appropriate use

The torque meter is highly accurate and resistant to rotational speed. The signals from the flange serve to control the test bench and to analyze the components.

The torque flange is used just for torque measurement tasks within the load limits in the specification (see Technical specs). Any other use is not permitted.



The torque meter is not allowed for use as a safety component.



The torque meter may not be used as pillow block.



Note

Stator operation is only permitted when rotor is installed as described in the mounting instruction.

2.4 Modifications/conversions

Any modifications/conversions of the design or safety engineering of the torque meter without the explicit agreement from ATESTEO will lead to the loss of warranty or liability. Any damages or injuries of personnel therefrom are in responsibility of the operator.

2.5 Operator's responsibility

Standards

The ATESTEO torque meter was designed and constructed taking account of a risk analysis and careful selection of harmonized standards and other technical specifications with which it complies. It represents the state of the art and guarantees a maximum degree of safety.

Qualified personnel

Qualified personnel are persons who by reason of their training, experience, instruction and their knowledge of the relevant standards, regulations, accident prevention rules and working conditions have been authorized by the person responsible for the safety of the machine/product to perform the appropriate activities required, and thereby are able to recognize and prevent potentially dangerous situations (For the definition of skilled workers see VDE 0 105 or IEC 364, which also regulate the prohibition of the employment of unqualified persons). Knowledge of first aid and the local rescue organization must also be available.

Transportation, assembly, installation, commissioning, maintenance and repair will be performed by qualified personnel or controlled by responsible skilled hands.

Safety relevant disconnecting device

The torque meter cannot implement any safety relevant cut-offs. It is in the operator's responsibility to integrate the torque meter into superior safety system.

The electronically acquired measurement signal should be designed so that measurement signal failure does not subsequently cause damage.

Residual risks

The power and scope of delivery of the torque meter covers only a subset of the torque measurement technology. Safety aspects of torque measurement technology must be planned, implemented and taken into account by the system planner, supplier or operator in such a way that residual risks are minimized. Each existing regulation must be observed. Attention should be drawn to residual risks associated with torque measuring technology.

In the case of a shaft break, you must ensure that there is no risk of injury. This should be done with a shaft protection cover in a closed test room with corresponding security doors. During operation, no person should stay in the test room.

Usage recommendations for personal protective equipment



Working in a workshop generally requires the wearing of safety shoes.



Use suitable gloves when handling corrosive or irritating solutions and adhesives.

Transport and storage

Check the delivery immediately for completeness and shipping damage.
Use working gloves during transport/ assembly/ maintenance.



Storage

- do not store outdoors
- store dry and dust-free
- do not expose to aggressive media
- protect from sunlight
- avoid mechanical shocks
- storage temperature according data sheet

If stored for more than 3 months, regularly check the general condition of all parts and packaging.

2.6 Safety notes for assembly



Stator bottom plate

The DST system must be properly mounted on the ground via the bottom plate (see 4.1.2.1).



Tightening torque

When tightening the screws, the specified tightening torques (see 4.1.2) must be observed.



Shaft alignment

The shaft of the DST must be aligned properly to avoid parasitic loads which influence the accuracy and could lead to damage.



Clutch installation

If a clutch is installed on the DST shaft, follow the mounting instruction of the clutch for proper installation.



Electric wire

All cables must be professionally laid according to the actual standards. The system must be grounded (see 4.2.2). Fuses according to national regulations must be used to protect the power supply of DST.



Rotating parts

Rotating parts must be grounded- risk of static electricity.

2.7 Safety notes for operation

As accident prevention a covering has to be fitted once the torque meters have been mounted. This is the fact if the torque meter is already fully protected by the design of the machine or by existing safety precautions. Please pay attention to following requirements for the covering as accident prevention:

The covering must not be free to rotate

Covering must be positioned at a suitable distance or be so arranged that there is no access to any moving parts within.

Covering should prevent squeezing or shearing and provide sufficient protection against parts that might come loose.

Covering must still be attached even if the moving parts of the torque flange are installed outside people's movement and working range.



Note

Improper use and handling as well as constructional changes will invalidate the EC declaration of conformity.



System measurement signals (speed or torque) may not be used for safety functions of the test bench without verification. Verifications such as Target/Actual comparison, plausibility check (grade analysis, peak analysis) or redundant signals for comparison must be implemented in the automation system. Error flags or information must be observed and handled by the automation program.

2.8 Load limits

Observe technical data sheets when using the torque meter. Pay particular attention to never exceed the respective maximum loads. For example:

- Load limits
- Torque oscillation width,
- Temperature limits,
- Longitudinal limit force, lateral limit force or limit bending moment,
- Limits of electrical load-carrying capacity,
- Limit rotation speed.

Limits are specified in the data sheet of the product.

3 System description

The DST combines torque measurement technology with integrated speed measurement technology in a smart, compact housing. The torque measurement values can be easily recorded via a USB interface on the PC or measured via the integrated precise high dynamic voltage output.



Figure 3-1 Photo of DST-System

3.1 Specifications

Power Supply	24V DC min. 0,5A
Sample rate of torque signal	2 Samples/s ... 2,000 Samples/s
Sample rate of speed signal	
n > 2,000 rpm	max. 2000 Samples/s
n < 2,000 rpm	n Samples/s
Lowest Speed, which can be measured	1 rpm (Speed < 1 rpm -> 0 rpm)
Highest Speed, which can be measured	30,000 rpm (Speed > 30,000 rpm is clipped* ¹)
Speed sensor type	Optical speed sensor, 60 ppr
Analog Output Range	Selectable 0..3 V, 0..5 V, 0..10 V, -3..+3 V, -5..+5 V, -10..+10 V
Max. Analog Output Range	-12..+12 V
Analog Output Signal	16 bit
Resolution	
Analog Output Impedance	50 Ohm
Filter	<i>Torque frequency, Torque over USB,</i> <i>Torque over Voltage-Out: Analog LP,</i> 7.2 kHz <i>Speed: no filter</i>
USB port	Emulated serial port, 921,600 Baud, 2 ... 2,000 Samples/s
Frequency outputs	Torque: RS422 Speed: RS422

Table 3-1 Specifications

¹ Described in chapter 7.1.6 Clipping

3.2 Features

The DST series provides the following features:

Disturbance insensitive fm transmission

Adjustable torque sampling rate from 2 Hz to 2 kHz

frequency output proportional to torque 60 kHz \pm 20 kHz

analogue output [V] proportional to torque with torque sampling rate

frequency output proportional to speed pulses

USB interface with emulated serial port

4 Installation

Before installation, check that all parts of the measuring system are present and not damaged.

Screw the measuring shaft with a nut to the test axle. Chapter 4.1 describes all parameters for tightening torques and fitting dimensions. The mounting plate must be screwed with decoupling on the test bench. The size and design of decoupling and boreholes are also described in chapter 4.1.

Now connect the plug to the measuring system. Please turn off the power source before connecting. The assembly of the cable is described in chapter 6.

Switch on the system. The software comes pre-configured. At factory setting, the frequency output at zero torque outputs 60 kHz. The modulation is 20 kHz in both directions. The voltage output generates 0 V at zero torque. The stroke is 10 V in both directions.

The system is ready to use!

4.1 Mechanical installation

4.1.1 Part list

The complete measuring equipment consists of the following parts:

- Torque meter
- Connector 12 pole female (cable assembly optional)
- Manual

4.1.2 Mounting

4.1.2.1 Mounting on ground

The DST is placed on a fix ground. Four screws at the bottom plate must be used for mounting. Use screws of type M5. The length of the screws depends on the environment. A minimum lengths of 12mm is suggested. The tightening torque is 6 Nm for screws of strength grade 8.8 (recommended) and 8 Nm for screws of strength grade 10.9.

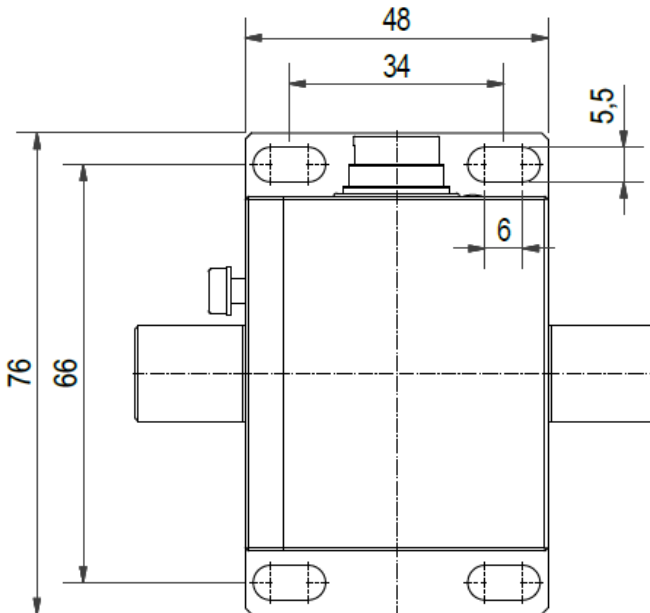

Figure 4-1 Top view with bottom plate for fixing

4.1.2.2 Mounting of shafts

The drive (motor) is connected to the shaft labelled with “IN”. The specimen should be connected to the shaft labelled with “OUT”. The shaft on the “OUT” side is the side with the installed measurement sensors. The single bearing is located on the side “IN”.

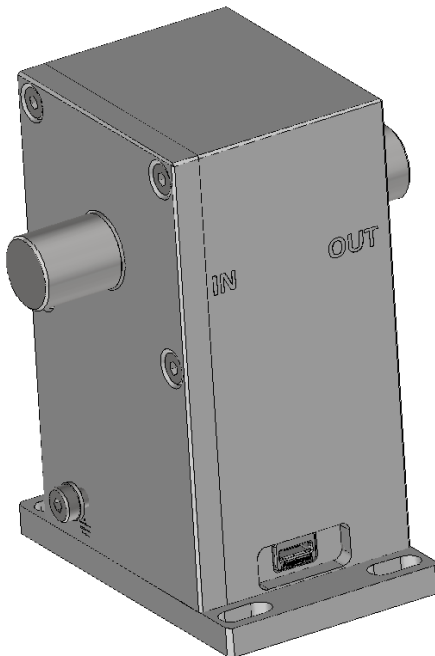

Figure 4-2 IN / OUT marks at the sides

4.1.3 Mechanical dimensions

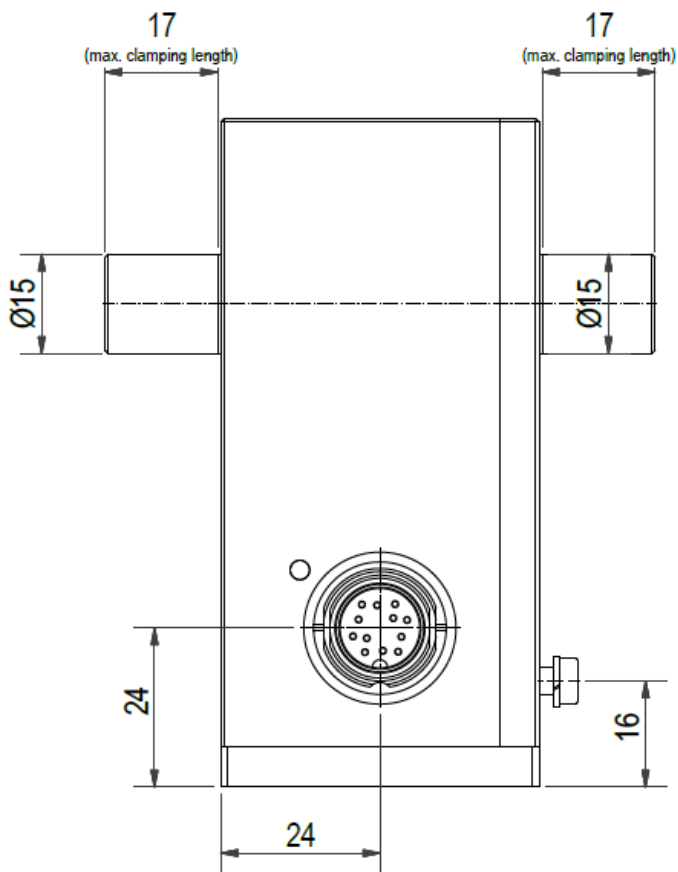

Figure 4-3 Front side view

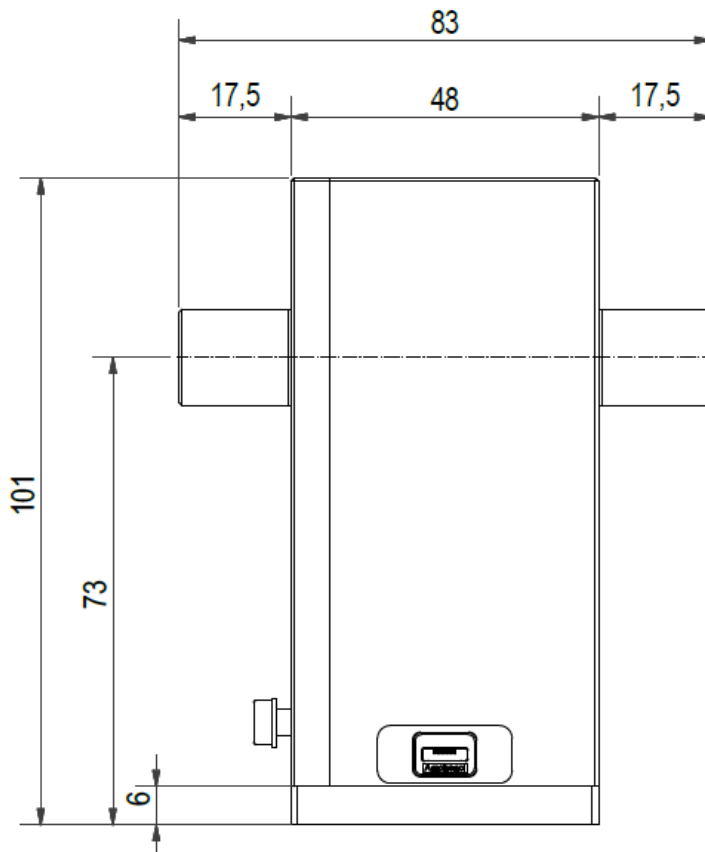

Figure 4-4 Back side view

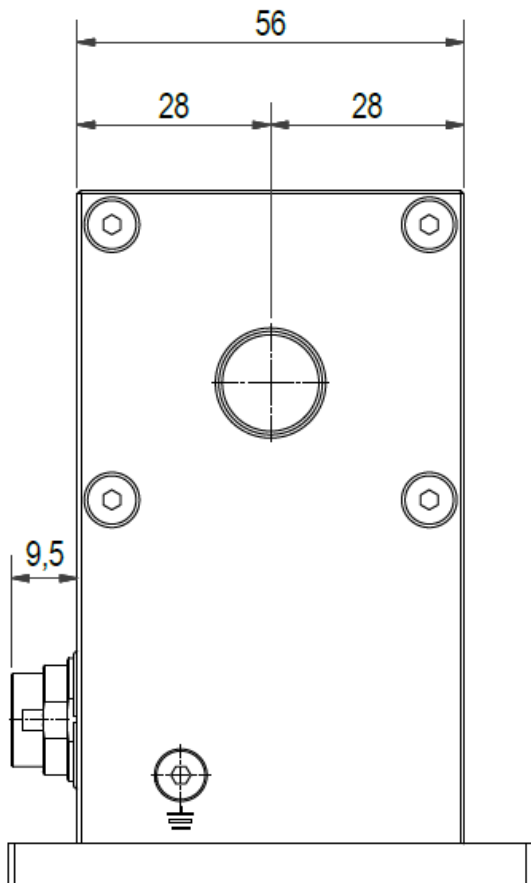

Figure 4-5 Side view A

4.2 Electrical installation

The parts delivered are dependent upon customer specific orders. If you have ordered a complete measurement system, all electrical and software parameters are pre-installed.

4.2.1 Power Supply

The purchased ATESTEO measuring system has to be powered with DC voltage of 24-30V / 1A. The power consumption range is 6 to 10 watts. The power supply must be protected with a 1AT fuse against overcurrent.

4.2.2 Earthing

The housing of the measuring system has an earth connection. The internal ground is separated from that earth. The torque meter **must** be connected to the earth of the test bench for proper working. Screws of the type M4 must be used.



Screw length

The maximum length of the screw is **8mm**. Longer screws could damage the electronic inside of the product!



Grounding screw

Figure 4-6 Grounding screw (side A)

4.2.3 Connecting the torque meter with a data acquisition system

Following the EMC standards (Standard EN61000-6-4 / VDE 0839 parts 6-4) requires application of the following steps: U

Use shielded servo cable with 4x 2x 0.14 mm² (twisted pair) and 4x 0.25 mm² wires.

The shielding of the cable must be connected to the connectors on both ends. The following grounding scheme is recommended:

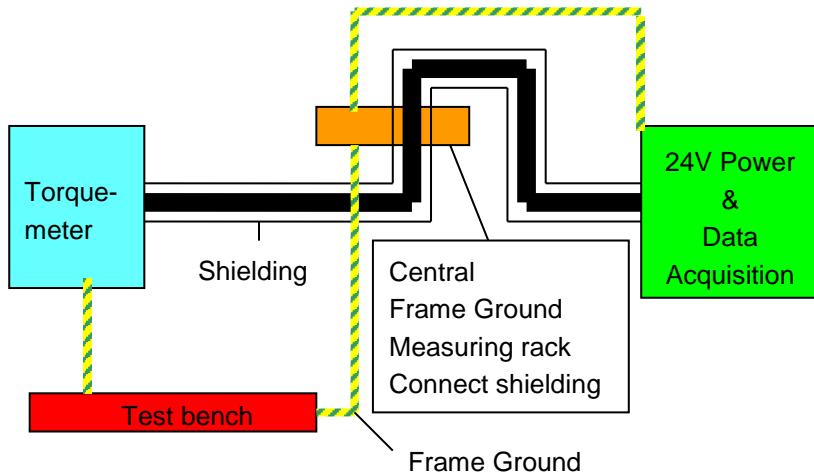

Figure 4-7 Grounding scheme

The shielding must be connected on both sides (torque meter and measuring rack).

The usage of the equipment assumes keeping the general safety regulations in mind!

5 Features & interfaces

5.1 Speed measuring system

The speed of the rotor is detected with an optical switch on the stator and a slotted disc on the rotor. The speed sensor is located completely inside the housing and is thus protected by external influences. The slotted disc generates 60 pulses per revolution. The pulses are ready for use as RS422 signal. Furthermore, the evaluation unit calculates the resulting speed. This can be recorded via the UART interface or system software.

5.2 Overvoltage protection

The measuring system is protected against overvoltage and reverse polarity. If the power LED on the meter body does not light up, check the wiring for reverse polarity and the power supply for excessive supply voltage. All outputs are short-circuit-protected.

5.3 Analog Output

The Analog Output converts the measured torque value into an analogue voltage value. The update interval is set via the UART interface in the following steps: 2 kHz, 1 kHz, 500 Hz, 200 Hz, 100 Hz, 50 Hz, 20 Hz, 10 Hz, 5 Hz and 2 Hz. There are four modes available for setting the voltage swing: 0 V – 3 V, -3 V – 3 V, -5 V – 5 V, 0 V – 10 V and -10 V – 10 V. In the unidirectional modes, the output value is limited from +/- 100% of the nominal torque. In the bidirectional modes, the output value is limited from +/- 110% of the nominal torque.

5.4 USB interface (UART interface)

The USB/UART interface can be used to connect the DST with any computer. When using the USB interface with Windows, the driver will be automatically installed by Windows. During installation, the DST can be detected as mouse. Movement and clicks are possible. It is recommended to plug the USB cable when computer is locked. Then wait for 5 minutes until the installation is completed.

5.4.1 Port settings

The following port settings are needed to use the simulated serial port:

Parameter	Value
Speed	921,600 Bd
Data	8 bit
Parity	none
Stop bits	1 bit
Flow control	none
Delays	none

Table 5-1 Overview of serial port settings

5.4.2 Sending information

The following commands can be executed with the UART interface:

Mainboard configurations	Rotor configurations
Activate test alarm output pin	Activate zeroing
Activate simulated values for torque	Activate Nominal value adjustment

Set torque sampling rate	Activate Test signal
Set DAC range	Activate strain gage short circuit
	Transfer / display data sheet
	Calibration value strain gauge supply voltage

Table 5-2 Overview of serial port settings

The commands are triggered as follows:

5.4.3 Command overview

Command to rotor	Action
Z	Zeroing
D	Nominal value adjustment
K	Test signal on
L	Test signal off
Q	Strain gauge short circuit on
W	Strain gauge short circuit off
S	Send data sheet
N	Activate data transfer
*	Stop data transfer

Table 5-3 Rotor command set overview

Command to main board	Action
A	Activate alert output (5 s)
B0	Simulate values off
B1	Simulate values -100% of rated torque
B2	Simulate values -50% of rated torque
B3	Simulate values 0% of rated torque
B4	Simulate values 50% of rated torque
B5	Simulate values 100% of rated torque

T1	Sampling rate = 2 Hz
T2	Sampling rate = 5 Hz
T3	Sampling rate = 10 Hz
T4	Sampling rate = 20 Hz
T5	Sampling rate = 50 Hz
T6	Sampling rate = 100 Hz
T7	Sampling rate = 200 Hz
T8	Sampling rate = 500 Hz
T9	Sampling rate = 1,000 Hz
T0	Sampling rate = 2,000 Hz
U0	DAC range $\pm 10V$
U2	DAC range 0V – 3 V
U3	DAC range $\pm 3V$
U4	DAC range 0V – 5V
U5	DAC range $\pm 5V$
U9	DAC range 0V – 10V

Table 5-4 Mainboard command set overview

5.4.4 Command details

5.4.4.1 Activate test alarm output pin

The command is triggered by pressing the 'A' key. The hardware alarm output remains active for 2s and automatically shuts off.

5.4.4.2 Activate simulated values for torque

The command is triggered by pressing the 'B' key. Then enter one of the following numbers to select the torque value to simulate. The simulated values are output via the analog output and the UART interface. The frequency output is not affected.

Number	Simulated value
'0'	No simulation
'1'	-100 % of rated torque
'2'	-50 % of rated torque
'3'	0 % of rated torque
'4'	+50 % of rated torque
'5'	+100 % of rated torque

Table 5-5 Overview of simulated values for torque

Other characters cause the routine to abort.

5.4.4.3 Set torque sampling rate

The command is triggered by pressing the 'T' key. The sampling rate affects the analog output and the UART interface. The frequency output is not affected. Enter one of the following numbers to select the sampling rate for torque:

Number	Sampling rate
'0'	2 Hz
'1'	5 Hz
...	<i>Same as command to main board</i>
'0'	2 kHz

Table 5-6 Overview of sampling rates and block filter values for UART-Interface

Other characters cause the routine to abort.

5.4.4.4 Set DAC range

The command is triggered by pressing the 'U' key. Then enter one of the following numbers to select the DAC-Range:

Number	DAC range		
'2'	0 V	–	3 V
'3'	-3 V	–	3 V
'4'	0 V	–	5 V
'5'	-5 V	–	5 V
'9'	0 V	–	10 V
'0'	-10 V	–	10 V

Table 5-7 Overview of different DAC ranges

Other characters cause the routine to abort.

5.4.4.5 Activate zeroing

The command is triggered by pressing the 'Z' key. The rotor must be unloaded during execution. The entry is automatically reset.

5.4.4.6 Activate nominal value adjustment

The command is triggered by pressing the 'D' key. The rotor must be loaded with the rated torque during execution. The input is automatically reset.

5.4.4.7 Activate test signal

The command is triggered by pressing the 'K' key. The test signal is applied to the current measured value. Therefore, it is important that the rotor is free of load during activation. The command is switched off again by pressing the 'L' key.

5.4.4.8 Activate strain gage short circuit

The command is triggered by pressing the 'Q' key. The inputs from the strain gage amplifier are shorted in this mode. The command is switched off again by pressing the 'W' key.

5.4.4.9 Transfer / display datasheet

The command is triggered by pressing the 'S' key. The rotor sends the rotor parameters to the stator. The parameters are transmitted by a modulation of the torque measured values. Therefore, the output at the analog output and at the UART interface is fixed to the last value, before the parameter transfer. The frequency output is not fixed during the parameter transmission.

The stator then generates a data sheet from rotor and stator parameters. The data sheet is sent directly after parameter reception via the UART interface. Further information on the data sheet can be found in the chapter "Receiving Information". Data reception continues immediately after the data sheet has been sent.

5.5 Enhanced system commands

The following commands are reserved for the calibration of the measuring shaft or the analogue output and should not be entered manually:

'C', 'P', 'V'

5.5.1 Receiving information

The received data stream is ASCII coded and in CSV format. Recorded measurements can thus easily be opened and evaluated with conventional spreadsheet programs. In the recorded measurement, each new line represents a new torque measurement. The update rate via the UART interface is always 2 kHz. For higher sampling rates, a block filter is applied to the UART output.

A line consists of four parameters separated by semicolons: Watchdog, torque, speed and system-state. The measured value representation is described below:

5.5.2 Watchdog

The watchdog is incremented by one with each newly calculated line. It counts from zero to nine. After nine, it starts again at zero. The watchdog value occupies one ASCII character from the line.

5.5.3 Torque

The torque is displayed as a relative value in Hz with one decimal place. The maximum positive and negative torque values are limited to $\pm 120\%$ of the nominal torque. The torque is calculated as follows:

$$M_{D,Nm} = (M_{D,Hz} - 60000 \text{ Hz}) \cdot \frac{M_{D,Rated}}{20000 \text{ Hz}}$$

$M_{D,Nm}$: Torque in Nm

$M_{D,Hz}$: Torque in Hz

$M_{D,Rated}$: Rated Torque in Nm

The torque value occupies seven ASCII characters (including decimal mark) from the line.

5.5.4 Speed

The rotor speed is given in rpm with one decimal place. The maximum speed value is limited to 120% of the rated speed. The speed value occupies seven ASCII characters (including decimal mark) from the line.

5.5.5 System state

The system status consists of 14 contiguous ASCII characters without separators in between. Each character describes the state of one system

component. In the following table, the ASCII characters are assigned to the associated system components:

Character position	System component
14 (left)	Torque sampling rate: 1: 2 Hz, 2: 5 Hz, ..., 0: 2 kHz <i>Same as command to main board</i>
13	Simulated values for torque: 0: off, 1: -100%, 2: -50%, 3: 0%, 4: +50%, 5: +100%
12	Torque overload: 0: off, 1: negative overload, 2: positive overload
11	Torque clipping ^{*2} : 0: off, 1: negative clipping ^{*2} , 2: positive clipping ^{*2}
10	Speed overload: 0: off, 2: positive overload
09	Speed clipping ^{*2} : 0: off, 2: positive clipping ^{*2}
08	Test signal: 0: off, 1: on
07	Strain gage short circuit: 0: off, 1: on
06	Zeroing: 0: off, 1: on
05	Nominal value adjustment: 0: off, 1: on
04	Datasheet transfer: 0: off, 1: on
03	DAC range: 2: (0V - 3V), 3: (-3V - 3V), 4: (0V - 5V), 5: (-5V - 5V),

² Described in chapter 7.1.6 Clipping

	9: (0V - 10V), 0: (-10V - 10V)
02	DAC calibration mode: 0: off, 1: 5573 digit, 2: 33771 digit, 3: 46370 digit, 4: 59969 digit
01 (right)	Data transfer 0: normal operation, 1: data transfer error

Table 5-8 Overview of system state indices

5.5.6 Datasheet

The datasheet mode is initialized by the 'S' key and 7 seconds after system startup. During transmission, the UART and analogue torque output is kept constant. Character position three of the system status identifies the active transfer. During transmission, no rotor-relevant data entries are permitted. After transmission of the data sheet via UART, the measure mode is continued with current torque values. The data sheet is composed as follows:

Line by line Representation	Description
* *	Start sequence for datasheet
Serial: XXXXX	Serial number of the measurement system
Firmw. Rotor: XX.YY	Firmware of rotor
Firmw. Stator: XX.YY	Firmware of stator
Rated Torque [Nm]: XXXXX	Rated Torque in Nm
Sensitivity [Hz/Nm]: XXXXX,XXXX	Sensitivity in Hz/Nm
Vs-Rotor [digit]: XXXX	Rotor supply voltage in digit
Temp. [digit]: XXXX	Current rotor temperature in digit
Temp.-Max [digit]: XXXX	Maximum reached rotor temperature in digit

Temp.-Fault [digit]: X	Error code for temperature sensor in digit: 0: ok, 1: fault
EEPROM-Fault [digit]: X	Error code for EEPROM in digit 0: ok, 1: fault
DAC-Value [digit]: XXXXX	DAC value for reference voltage of strain gauge bridge in digit
Comp.-Value [digit]: XXXXX	DAC value for temp. compensation in digit

Table 5-9 Overview of datasheet

X and Y represent the number of characters for each value. The decimal separator is comma.

The digit values for “Vs-Rotor”, “Temp.” and “Temp.-Max” can be converted into natural quantities as follows:

5.5.7 Vs-Rotor

$$U_{VOLT} = 0,024862 \frac{V}{digit} \cdot (U_{DIGIT} - 2 digit)$$

U_{VOLT} : Rotor voltage in V

U_{DIGIT} : Rotor voltage in digit

5.5.8 Temp. & Temp.-Max

$$T_{°C} = 0,0625 \frac{°C}{digit} \cdot T_{DIGIT} - 40 °C$$

$T_{°C}$: Temperature in °C

T_{DIGIT} : Temperature in digit

5.5.9 Digital Interface

Activate zeroing

Set Control for 5 seconds. With the falling edge of the input signal the zero point is calibrated.

Test signal

Set Control for 7 seconds. After 7 seconds the test signal will be engaged as long as the signal has a voltage level of 24V. By setting Control=0V the test signal will be disabled.

Alarm Md/N

If the alarm thresholds have been exceeded due to overload or over-speed the open collector outputs "Alarm Md" and "Alarm N" are set. The digital outputs are open-collector types, so that the measured output signal is inverted. The maximum collector-emitter voltage is maximum rated with 36V (50mA).

For circuit details and sample circuit please refer to chapter „Electrical specifications“.

Alarm IR

If the data transmission between the rotor and the stator can no longer be guaranteed faultless, the output "Alarm IR" is set. The degree of failure is observed by monitoring the intensity of infrared-light being transmitted. The threshold is factory calibrated and cannot be altered.

For circuit details and sample circuit please refer to chapter „Electrical specifications“.

Reset Alarm

If alarm thresholds are exceeded the corresponding digital output is set. With the help of the input "Reset Alarm" it is possible to reset the alarms

being displayed. The status bits are also cleared when using this feature. Apply a voltage >4V to trigger the reset function. The maximum input voltage is rated with 30V.

For circuit details and sample circuit please refer to chapter „Electrical specifications“.

5.6 LED

After powering up, the system will reflect its status via the status LED built into the chassis. The color and pulse encoding is displayed first with the highest display priority in the following overview:

Prio.	Color	Frequency	Description
1	Turquoise	16 Hz (very-fast)	Active datasheet transmission
2	Blue	2 Hz (slow)	Zeroing active
3	Purple	2 Hz (slow)	Test signal active
4	Red	ON	No data transfer
5	Orange	8 Hz (fast)	Torque or speed clipping ^{*3}
6	Green	8 Hz (fast)	Torque or speed in overload
7	Green	2 Hz (slow)	Normal operation

Table 5-10 Overview of Status LED encoding

³ Described in chapter 7.1.6 Clipping

6 Connections

6.1 Plug connection at DST

6.1.1 X800

12 pol male Binder plug. Please use matching female connector described in 6.2.1.

6.1.2 USB

Micro-B USB 2.0 plug male	
Pin	Description
1	Supply voltage (\downarrow_D)
2	Data _{DIFF-} (\downarrow_D)
3	Data _{DIFF+} (\downarrow_D)
4	Not connected
5	Supply GND (\downarrow_D)

Table 6-1 Pin description of micro USB connector.

6.2 Cable connection

6.2.1 X800

X800 - Cable 12 pol M16 female			
Pin	Description	Wire type	Wire color
A	Analog GND (\downarrow_A)	0.14mm ² - twisted pair	Blue
B	Analog out, M _d (\downarrow_A)	0.14mm ² - twisted pair	Red (thin)
C	Digital GND (\downarrow_D)	0.25mm ²	Black
D	Test signal in (\downarrow_D)	0.25mm ²	White

X800 - Cable 12 pol M16 female			
Pin	Description	Wire type	Wire color
E	M _{df} -out _{DIFF+} (⊥ _D)	0.14mm ² - twisted pair	Green
F	M _{df} -out _{DIFF-} (⊥ _D)		Yellow
G	N-out _{DIFF-} (⊥ _D)	0.14mm ² - twisted pair	Grey (thin)
H	N-out _{DIFF+} (⊥ _D)		Pink
J	Supply voltage (⊥ _S)	0.25mm ²	Red (bold)
K	Alarm-out (open collector)	0.14mm ² - twisted pair	Grey (bold)
L	Zeroing in (⊥ _D)	0.14mm ² - twisted pair	Brown
M	Supply GND (⊥ _S)	0.25mm ²	Purple

Table 6-2 Cable description for connector X800.

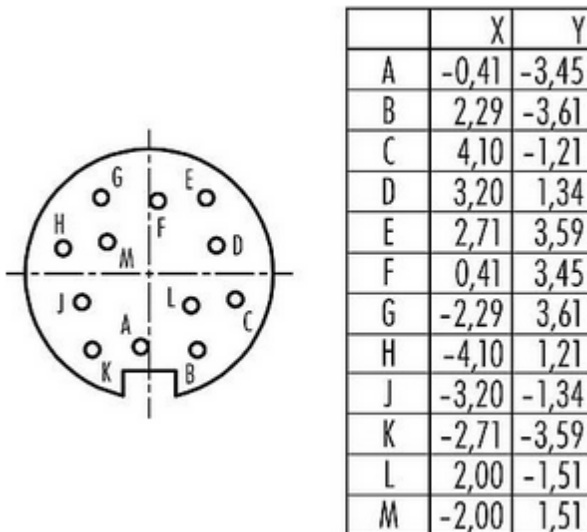

Figure 6-1 Pin position at Binder plug (female)

6.2.2 USB

Use a commercially available USB-Micro-B to USB-A adapter cable to connect the measuring system to a PC with USB-A interface.

7 General references

7.1 Resetting the zero point

With each measuring element, from a flexible spring element that is measured by its elastic deformation, there will always be a zero drift even if no load is applied.

Related to DMS based Torque measuring systems, zero-drifts in a load-free condition can be caused by the following circumstances:

7.1.1 Thermal influences

Despite of a complex temperature compensation a zero-drift related to high temperature fluctuations can always be observed. Due to various temperature influences interacting permanently with the torque meter, another reason for exiguous zero-drifts is given.

The temperature stability defined in the technical specifications, e.g. 0.1%/10°K is determined by the allowed temperature drift of $\pm 0.1\%$ of the rated torque per 10° Kelvin difference.

7.1.2 Hysteresis-caused influences

If a sensor during a test is mostly loaded in one direction it can indicate a drift after the test is terminated. This drift cannot to be traced back to a temperature compensation problem but to the natural hysteresis of the sensor and strain gauges.

The change of the zero value depends on the torque applied or on the test duration. In any case, the value of the zero-drift variation will not be larger than the linearity and hysteresis specified in the technical data for the sensor.

7.1.3 Aging

If a strain gauge based sensor is dynamically loaded for a long period of time a zero-drift can occur. This value depends on the cycle count and the strain amplitude. This zero-drift will affect the sensitivity of the sensor. Even though this is a natural effect for strain gauge sensors, ATESTEO torque sensors drift is very low due to a low sensitivity at nominal torque.

7.1.4 Lateral force influence

Considering that each torque sensor is part of a powertrain, every component linked to the sensor generates a lateral force. This load will be influenced by the size and installation of the components. This lateral force will be added to the measuring signal. If the installation is performed as specified in the technical specifications, this influence will be extremely small.

7.1.5 General

All the above mentioned items that influence the zero-drift are still in the range of calibration tolerance, as long as the sensor is properly maintained and handled and no transportation damages occurred to the sensor or strain gauges.

Due to the fact that all the above mentioned zero-drifts can happen in different situations at the same time it is very difficult to suggest a general zero-reset procedure.

After considering all the information acquired through our experience and customers feedback we can suggest and comment different scenarios for a proper zero-reset of the torque sensor.

- A zero-reset is only allowed if the torque is zero.
- If a great zero shift (>10 Hz) is observed during the mounting of the torque meter please check the adapter flange due to the mechanical properties. A lower zero-shift can be reset.
- The test bench engineer has to decide, whether the accuracy request of the actual test requires a reset of the zero point. Generally it is possible to improve the accuracy by resetting the zero torque after the warming-up period of the test stand and before starting the measurement.
- If the zero shift is greater than 2% of the rated torque, the torque meter must be checked. These tests (recalibration and other tests) have to be done by ATESTEO to find out the reason for the malfunction.
- A zero shift of 0.05% of the rated torque per month has no influence to the accuracy of the system.

7.1.6 Clipping

When a signal is clipped, the measurement signals that exceed a certain limit value are clipped to this limit value.

7.2 CE Manufacturer's Declaration:

The manufacturing's declaration is a separate document which can be sent on demand.

8 Appendix

8.1 Table of figures

Figure 3-1 Photo of DST-System.....	17
Figure 4-1 Top view with bottom plate for fixing	21
Figure 4-2 IN / OUT marks at the sides	22
Figure 4-3 Front side view.....	23
Figure 4-4 Back side view	24
Figure 4-5 Side view A	25
Figure 4-6 Grounding screw (side A)	27
Figure 4-7 Grounding scheme	28
Figure 6-1 Pin position at Binder plug (female)	44

8.2 Table of tables

Table 3-1 Specifications.....	18
Table 5-1 Overview of serial port settings.....	30
Table 5-2 Overview of serial port settings.....	31
Table 5-3 Rotor command set overview	31
Table 5-4 Mainboard command set overview	32
Table 5-5 Overview of simulated values for torque	33
Table 5-6 Overview of sampling rates and block filter values for UART- Interface	33
Table 5-7 Overview of different DAC ranges	34
Table 5-8 Overview of system state indices	39
Table 5-9 Overview of datasheet	40
Table 5-10 Overview of Status LED encoding	42
Table 6-1 Pin description of micro USB connector.	43
Table 6-2 Cable description for connector X800.	44



Excellence in drivetrain testing

Want to learn more about our products, solutions and services in the fields of measurement systems, vehicle equipment and actuators? Then please call us at +49 2404 9870-570 or email us at equipment@atesteo.com. Your personal ATESTEO contact is always at your disposal.

ATESTEO GmbH & Co. KG
Konrad-Zuse-Str. 3
52477 Alsdorf
Germany

Telephone +49 2404 9870-580
E-Mail service-pm@atesteo.com
www.atesteo.com